

MONOPROFILE
TRANSFER SYSTEM

TM SERIES



TRAN  EPT

The advantages of a good design

Index

<u>Topics</u>	<u>Page</u>
Main features.....	2
Applications.....	3
Motorized section.....	4
Connecting plates between sections / Leg sets / Hardened steel rolling profiles.....	5
Electrically operated rotary table.....	6
Pneumatically operated sliding table.....	7
Electrically operated lift.....	8
Electrically operated rotary transfer table.....	9
Shuttle.....	10
Pneumatic dampened stop unit / Shuttle positioning at the working place.....	11
Stop at section end / Sensor support / Mechanical antireturn device / Pneumatically antireturn device.....	12

TM type monoprofile transfert system : ergonomomy at the working place

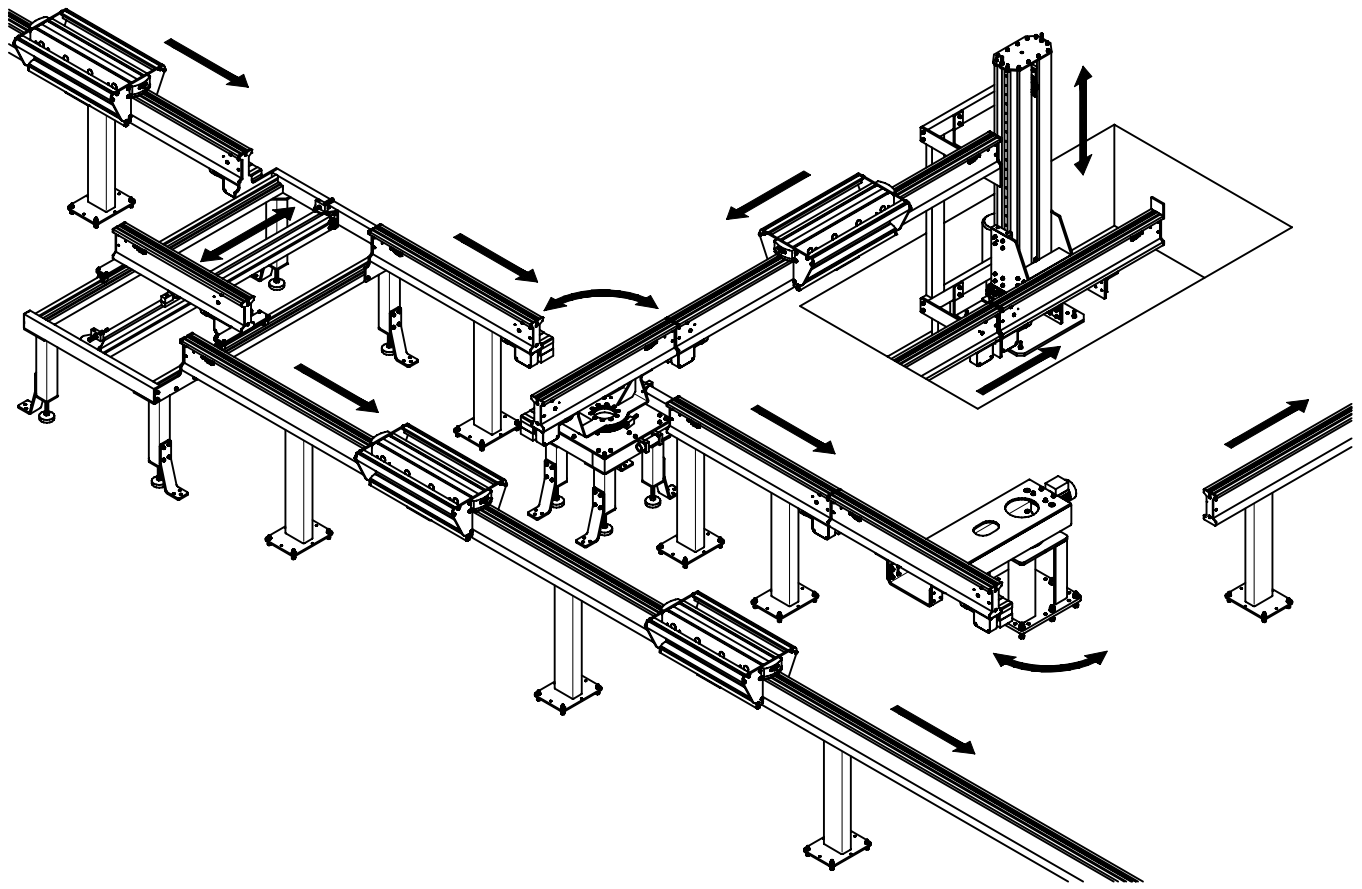

Main features

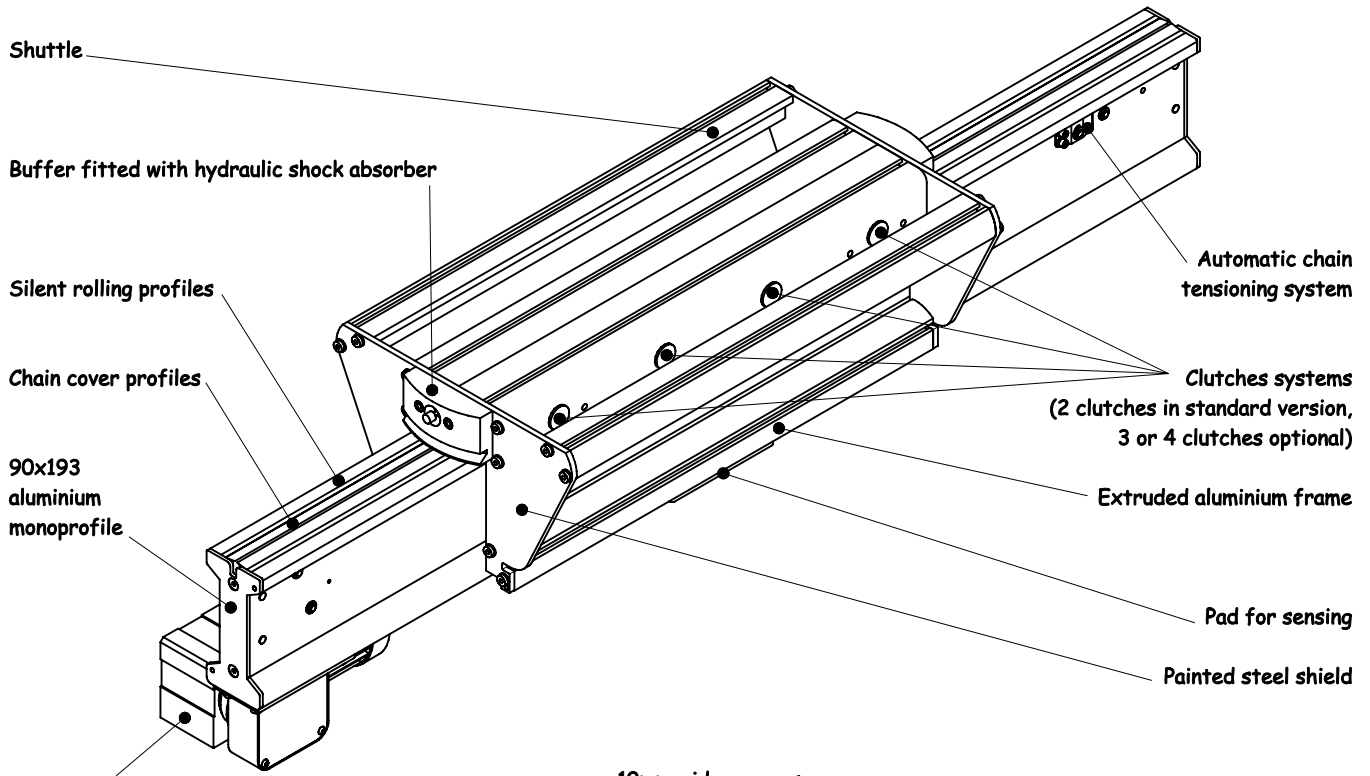

SEW compact motorization allowing forward and backward functioning

10mm wide grooves for fixing of fixture

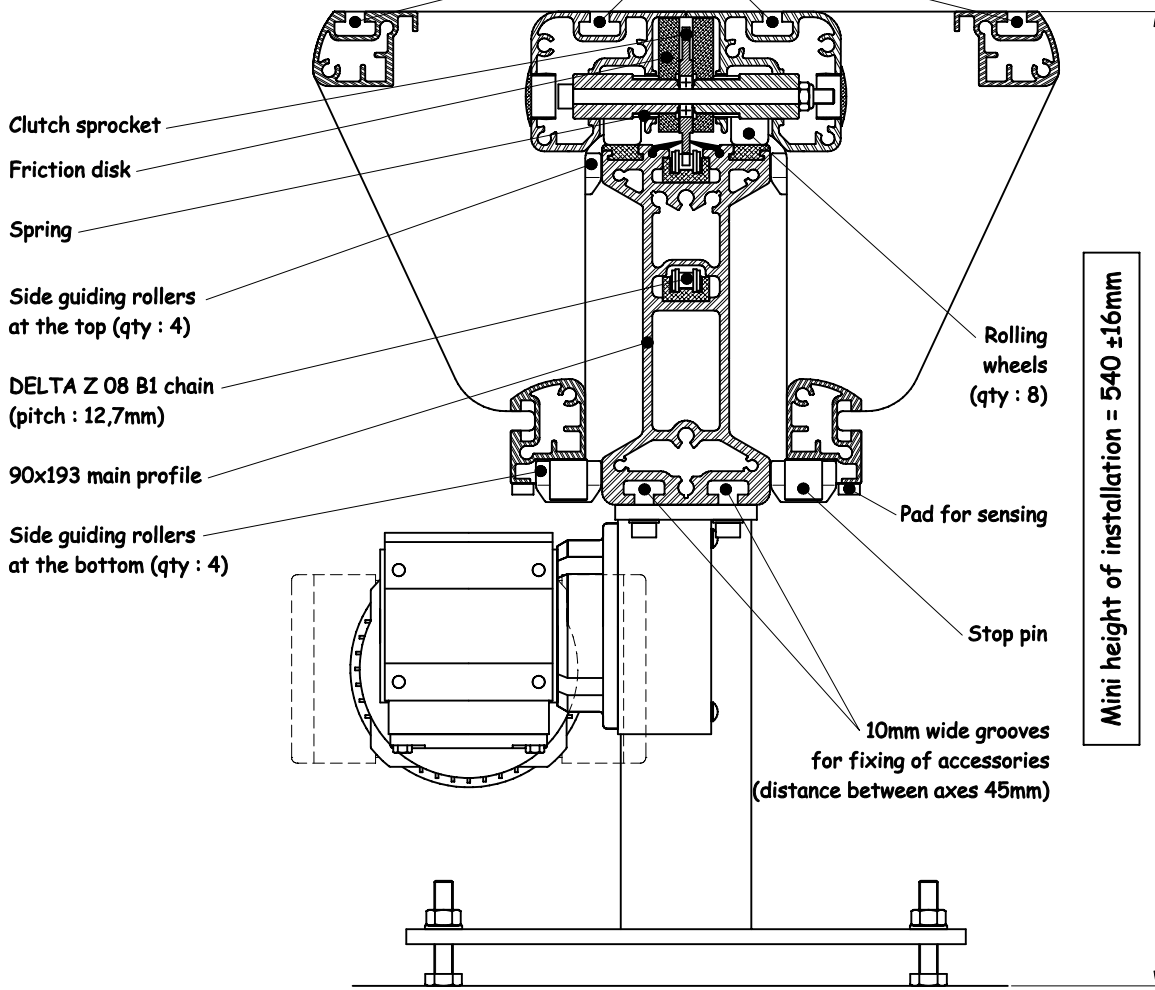

Applications

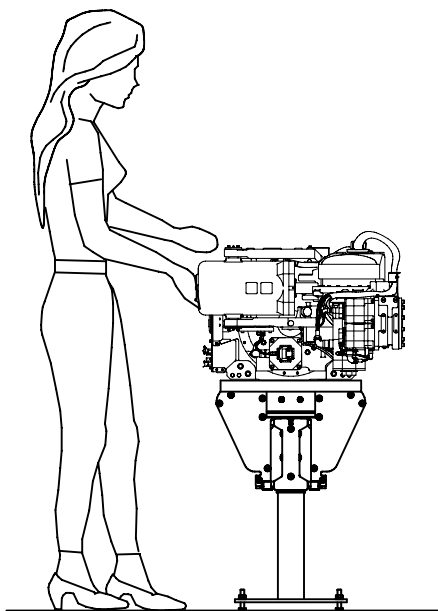

Its compact overall dimensions and the optimal ergonomics provided by the system facilitate the arrangement of the working place.

Sections are motorized and shuttles are driven by a passive and progressive clutch system. The operator can anytime safely stop the soft and smooth flow.

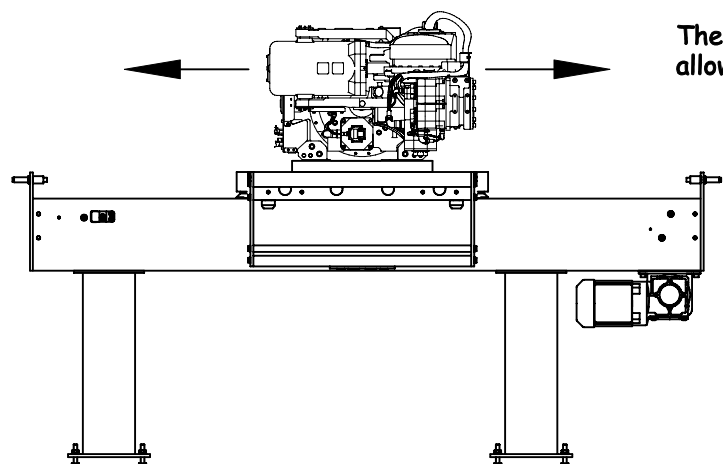

The forward and backward functioning of the system allows specific applications such as loading and unloading.

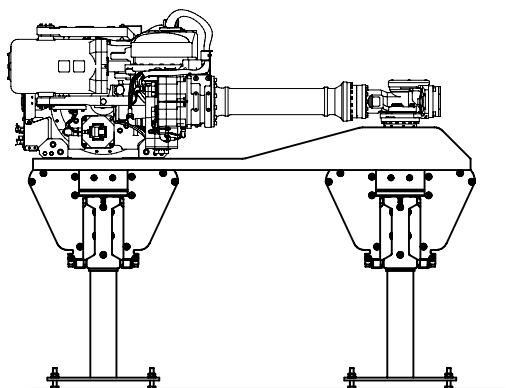

Transportation of voluminous and / or heavy products is also possible thanks to a twin arrangement of the sections.

Motorized section

Nominal speed of the line : 15m/min (standard speed)
 Speed on request : from 3 to 35m/min
 Automatic chain tensioning
 Possible forward and backward functioning
 W20 type SEW motorreducer 180w 230/400V 3-phased

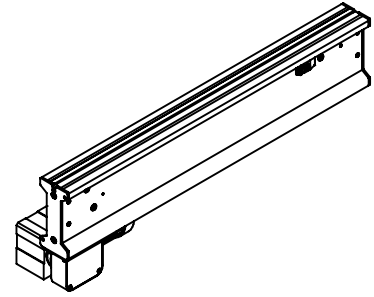

The loading capacity of the section will depend on the quantity of shuttles stopped in accumulation.

Speed (m/min)	Capacity
10	40 shuttle clutches
15	30 shuttle clutches
20	25 shuttle clutches
24	20 shuttle clutches

Mini section length 600mm
 Maxi section length 12880mm

Reference 2288 not fitted with lengthening element ($L \leq 6380$ mm)
 Reference 2298 fitted with lengthening element ($L > 6380$ mm)

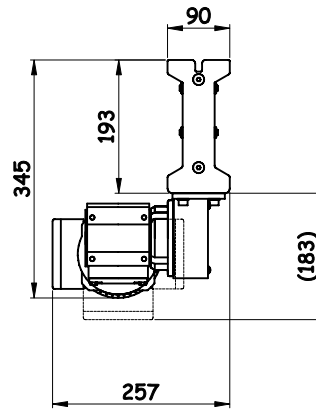

Reference to be ordered
 Example of a section $L=3500$ mm
 motorization on the left side, standard speed,
 standard position of the terminal.
 Ref.2288 Left - 3500

Motorization on the left side (on request)

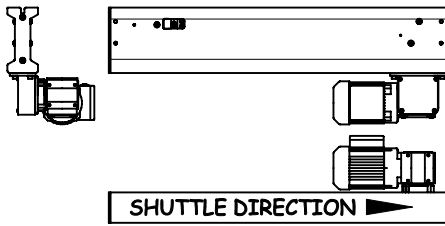

Motorization on the right side (standard position)

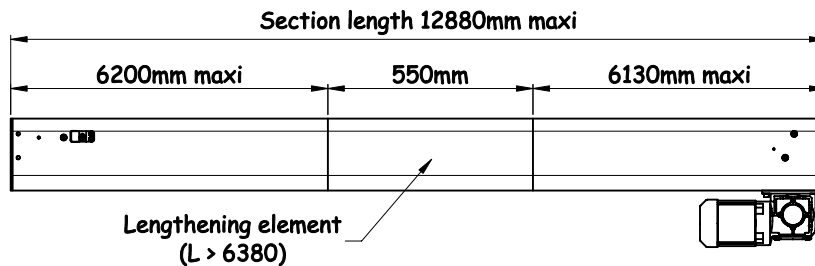
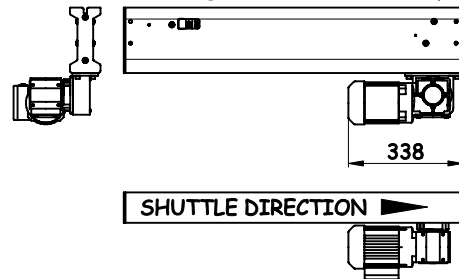

Fixing kits for alignment of sections

By assembly of sections in series (aligned), fixing kits ref.2215 and 2216 ensure perfect alignment of the sections.
 Fixing kit ref.2216 eases access to the sections ends (maintenance).

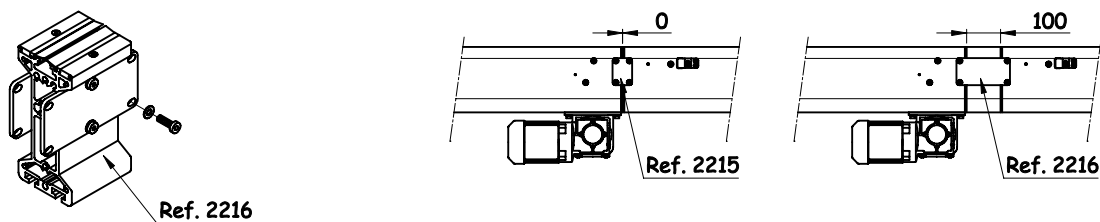

Leg sets

The leg sets are supporting the sections (section fixing bolting is supplied).

Aluminium leg set
 (80x80)
 Ref. 2100

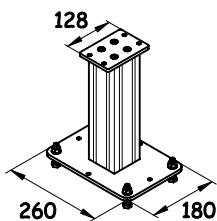

Painted steel leg set
 (140x70)
 Ref. 2110

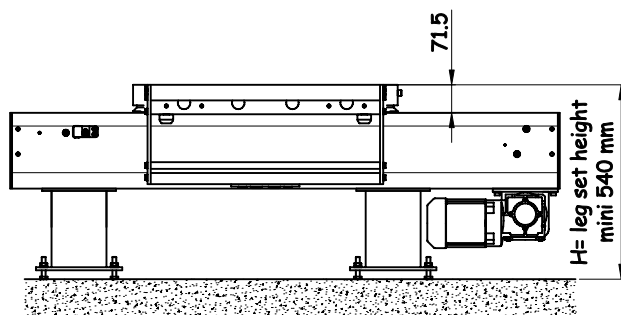
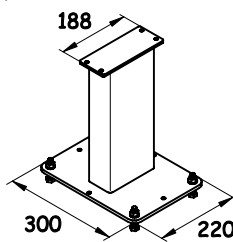

Hardened steel rolling profiles

In standard version, the motorized sections of rotary, transfer, sliding tables and lifts are fitted with hardened steel rolling profiles.
 These profiles can also be set at the working places on the motorized sections of the main line in order to reduce wear generated by external efforts.

Reference 2236 (set of 2 pces)

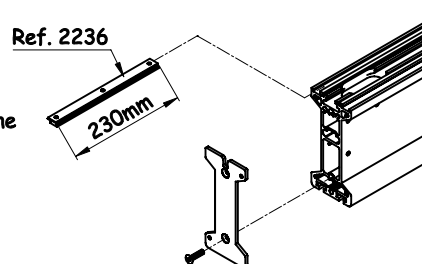

Electrically operated rotary table

Rotation by means of a SEW motorreducer 120w 230V or 400V 3-phased (monovoltage)
 Hydraulic shock absorber (2) and M12x100 (2) end travel sensors (2) (supplied)
 Rotation position: 90° and 180°
 Other position on request

Reference 2013 (section to be ordered separately)
 (stop unit to be ordered separately)
 (sensor support to be ordered separately)

Note: The motorised section is delivered fitted with hardened steel rolling profiles.

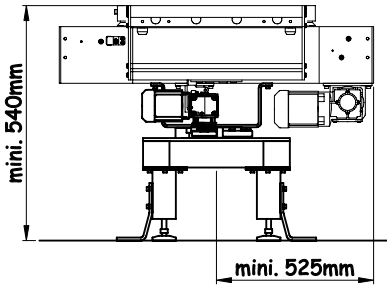
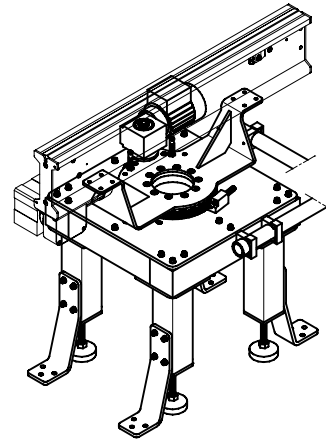

Shuttle	Section length	
	With stop unit 2016	With stop 2027 or 2028
500mm	1050mm Diameter: 1055mm	830mm Diameter: 1055mm
600mm	1050mm Diameter: 1055mm	880mm Diameter: 1055mm
800mm	1050mm Diameter: 1055mm	980mm Diameter: 1055mm
1000mm	1110mm Diameter: 1155mm	1110mm Diameter: 1115mm
1200mm	1310mm Diameter: 1315mm	1310mm Diameter: 1315mm

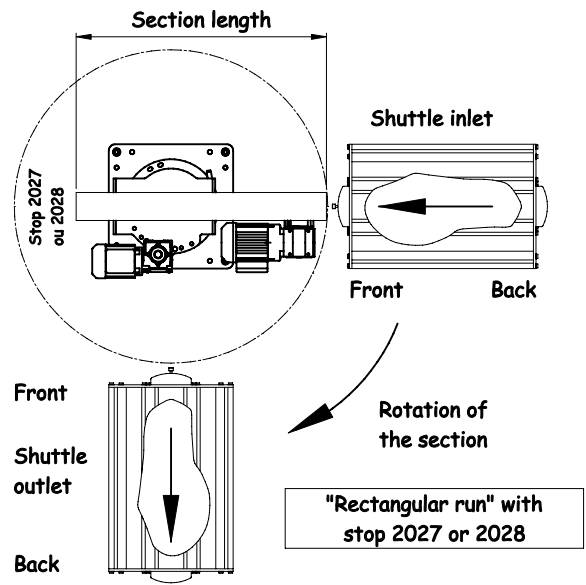
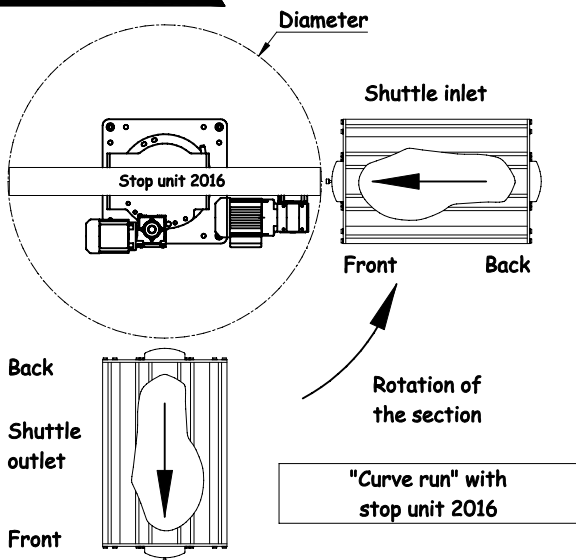

Possible configurations

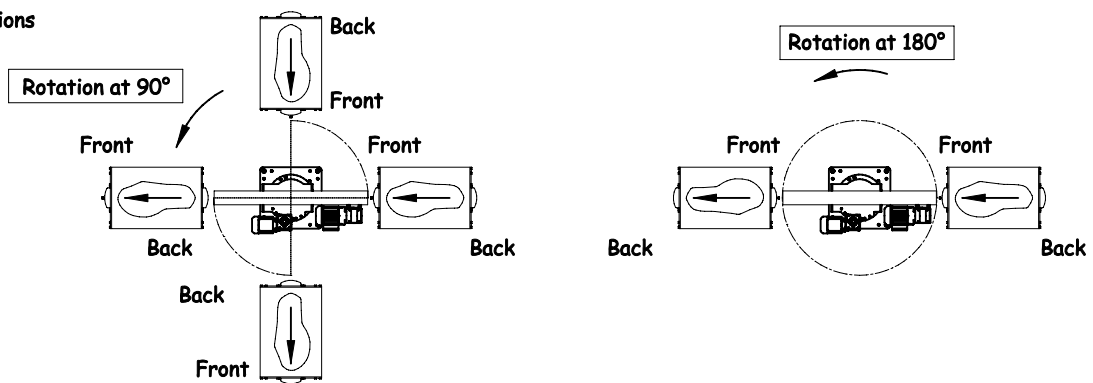

Pneumatically operated sliding table

Movement by means of a rodless pneumatic cylinder Ø50mm
 Flow limiters connections Ø8mm (supplied)
 2 sensors located on the cylinder (supplied)
 End travel hydraulic shock absorbers (supplied)

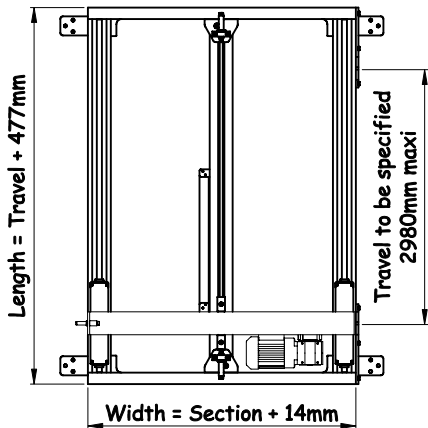
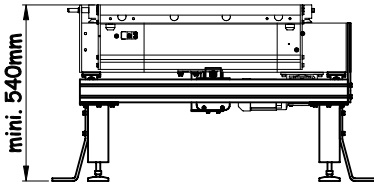
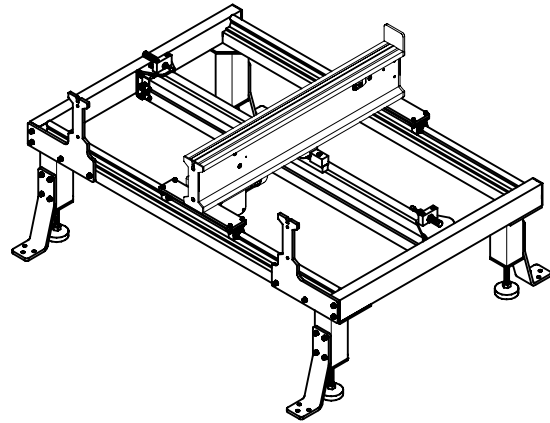

Shuttle	Section length	
	With stop unit 2016	With stop 2027 or 2028
500mm	950	900
600mm	1000	950
800mm	1100	1050
1000mm	1200	1200
1200mm	1400	1400

Reference to be ordered

Example of a shuttle 800mm, section 1050mm,
 travel (distance between axes) 1500mm

Reference 2014 - 800 - 1050 - 1500
 (section to be ordered separately)
 (stop unit to be ordered separately)
 (sensor support to be ordered separately)

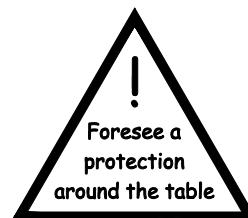

Note: The motorized section is delivered fitted with hardened steel rolling profiles.

Possible configurations

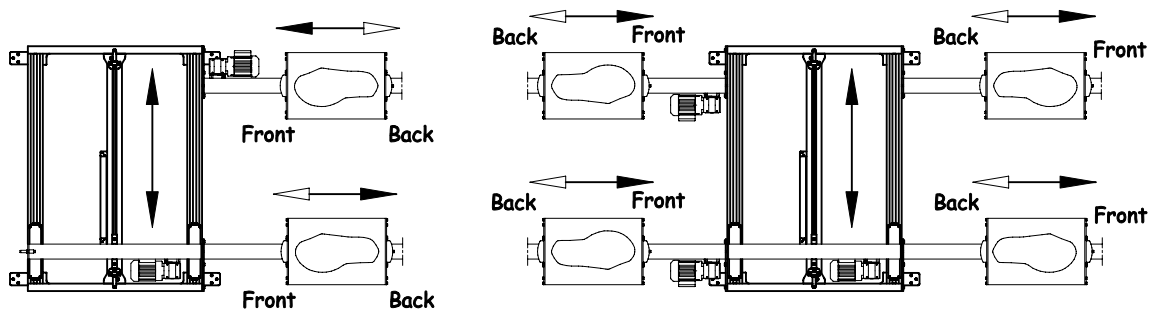

Electrically operated lift

Movement by SEW motorreducer 550w motor brake 230/400V 3-phased.
 Nominal speed 13m/min.
 4 end travel sensors (supplied)
 The use of a frequency inverter is advisable.

Reference to be ordered
 (section to be ordered separately)
 (stop unit to be ordered separately)
 (sensor support to be ordered separately)

Reference 2030 indicating,
 the height of installation (distance from
 the ground to the top of the shuttle)
 lift travel
 fixture width

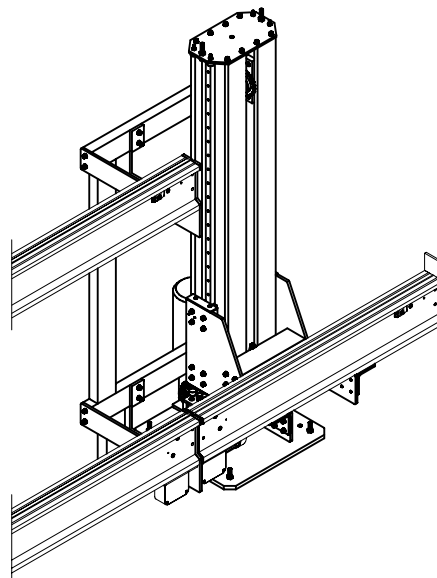
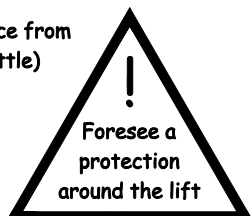

Note: The motorized section is delivered fitted with hardened steel profiles

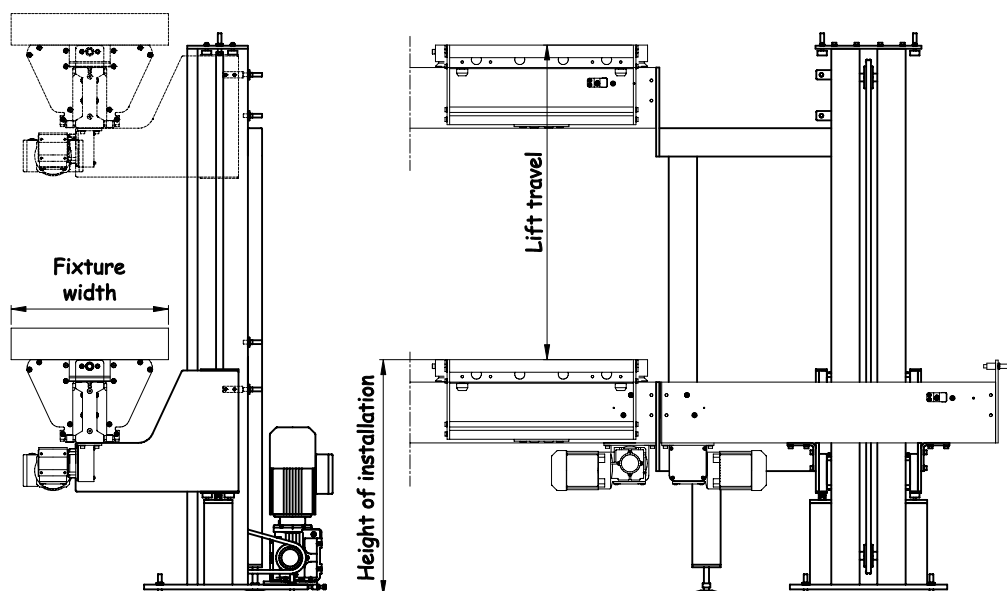

Possible configurations

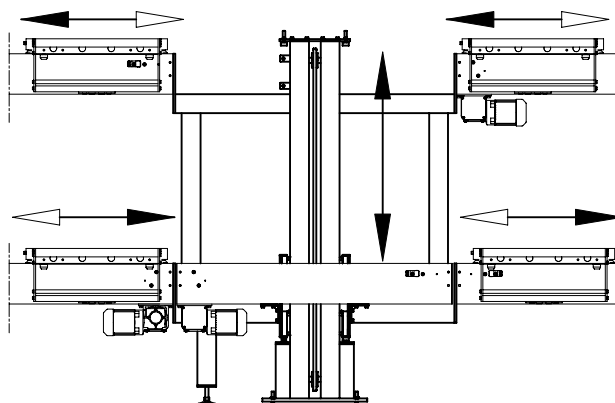

Electrically operated rotary transfert table

Rotation by means of a SEW motorreducer 180w 230/400V 3-phased
Rotation position 180° (other position on request)
4 end travel sensors (supplied)
2 end travel hydraulic shock absorbers (supplied)
The use of a frequency inverter is advisable

Reference to be ordered
(section to be ordered separately)
(stop unit to be ordered separately)
(sensor support to be ordered separately)

Reference 2032 indicating,
The height of installation (distance from the ground to the top of the shuttle)
Distance between axes of the sections
Length of the shuttle

Note: The motorized section is delivered fitted with hardened steel profiles

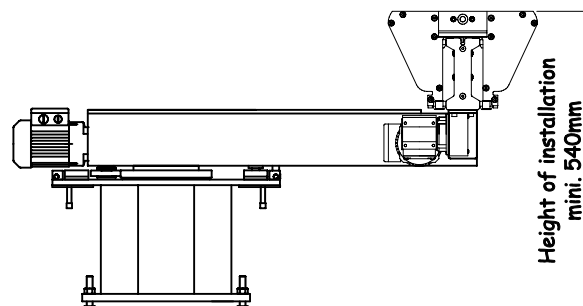
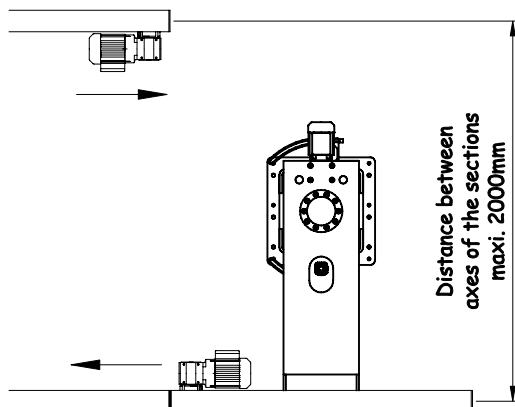
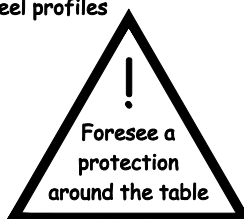
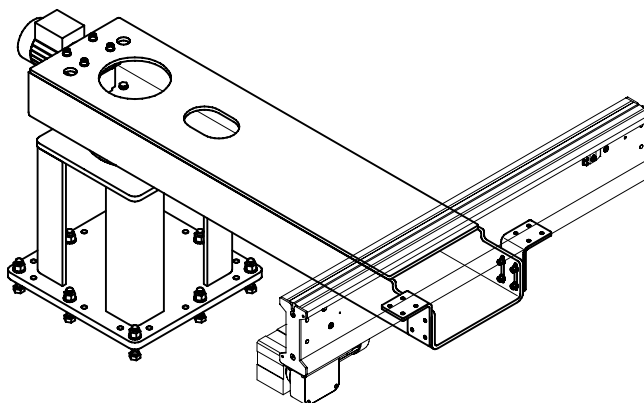

Shuttles

Maxi. payload **100Kg** (above, on request)
 Available standard lengths 500mm, 600mm, 800mm, 1000mm, 1200mm
 Adjustment and maintenance-free friction clutch
 2 clutches are set in standard version
 Extra clutches, offset or inclined shuttles,
 specific length: on request

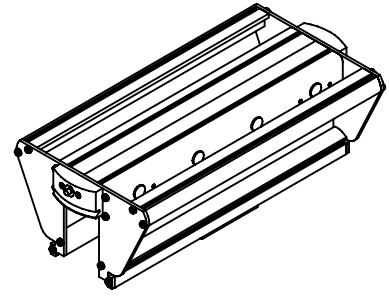

Note: Empty shuttle weight = 14Kg/m + 10Kg

Length (mm)	500	600	800	1000	1200
Reference	2000	2001	2002	2003	2004

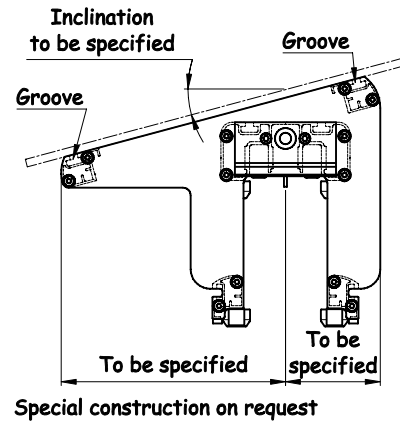
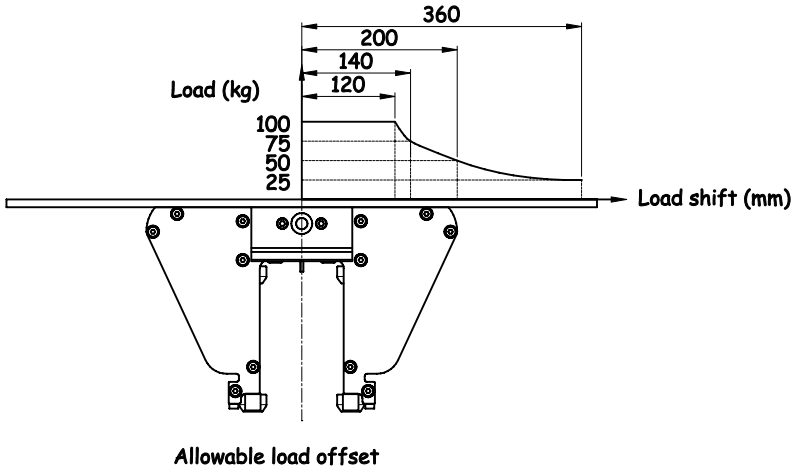
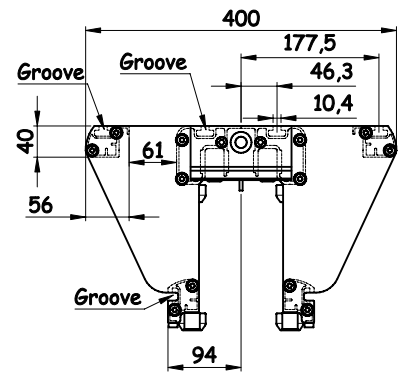
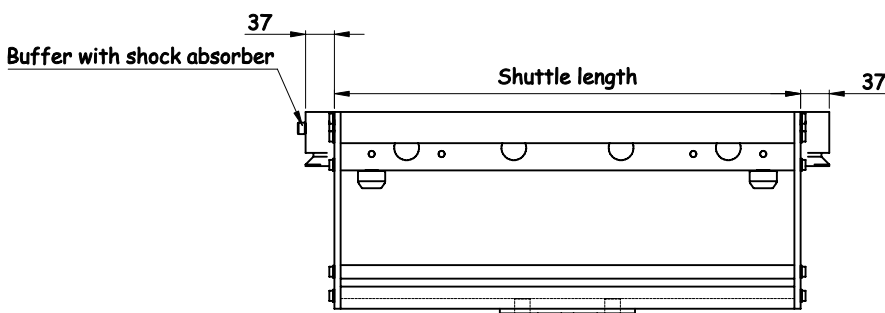

Dampened stop unit

Reference 2016

Stop unit ref. 2016 provides shuttle stop and detection at the working places and when approaching tables or lifts. A swinging mechanism dampens the shuttles stop by acting on a hydraulic shock absorber which is incorporated and protected in the stop unit body. This mechanism will be re-armed as soon as the shuttle has been released by the stop unit. A stop unit can also be fitted with 2 shock absorbers (on request)

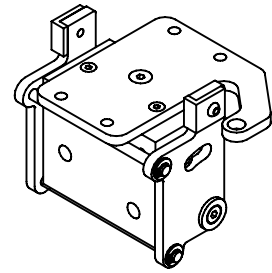

Simple effect pneumatically actuated stop unit (load capacity : 5 shuttles).

Lubricated or not lubricated, cleaned air, 5 to 6 bar.

Connection for Ø6mm pipe (supplied).

Shuttle detection by means of M12x100 sensor (not supplied). Advisable swept area 4mm.

Detection of stop unit high and low positions by means of M12x100 sensors (not supplied).

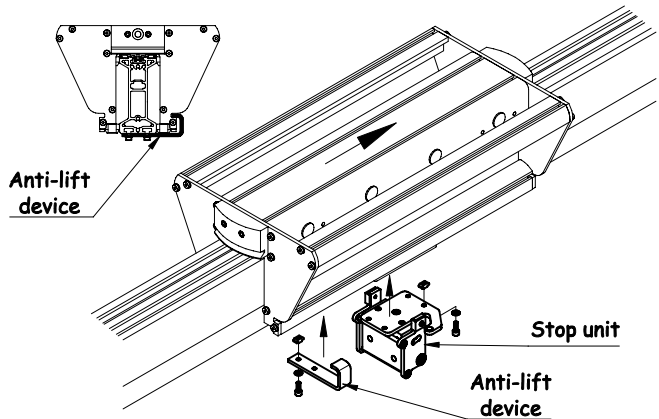
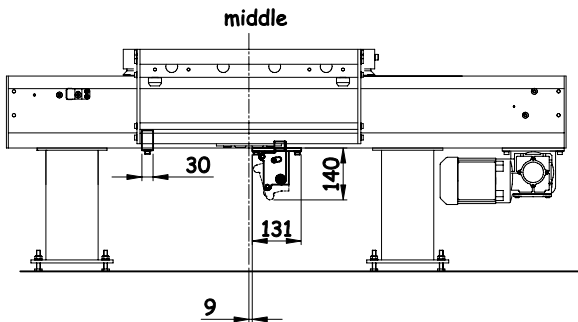

The anti-lift device located towards the rear of the shuttle may be set at the right or left side of the section. This device is necessary if accumulation of shuttles is needed.

Caution, you will not be able to use the anti-lift device if the shuttle is fitted with positioning links ref. 2033.

See shuttle positioning (below).

Shuttle positioning at the working place

This system keeps the shuttle in position at the working place.

The shuttle is stopped by stop unit 2016 (not supplied).

Positioning links ref. 2033 located on the shuttle get inserted inside rising devices ref. 2034.

The membrane cylinders of these devices rise the shuttle above the section (4mm), and allow a vertical effort of 240daN (including shuttle) at an accuracy of ±3mm.

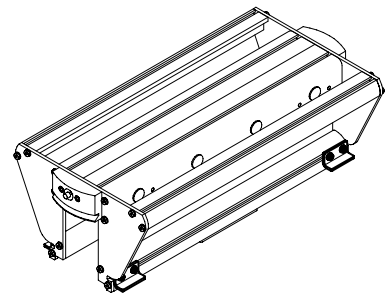

Note: This system does not allow the use of the anti-lift device set on the section.

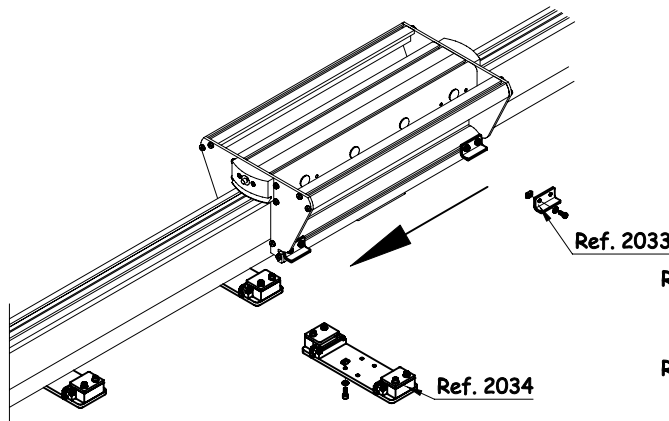

Ref. 2033 : suitable for one shuttle
(supply of 4 positioning links)

Ref. 2034 : suitable for one working place
(supply of 2 rising devices)

Stop at the section end

Stop unit ref. 2016 is necessary for "curve run" (rotary or transfer table) and for "sliding run" (sliding table or lift) because the shuttle direction remains unchanged.

But for "rectangular run" (rotary, sliding table or lift) stop unit ref. 2016 can be replaced by a stop at the section end ref. 2027 (without shock absorber) or ref. 2028 (with shock absorber) because the shuttle direction is reversed after passing through the tables or lift. Shuttle detection is provided by sensor support ref. 2017.

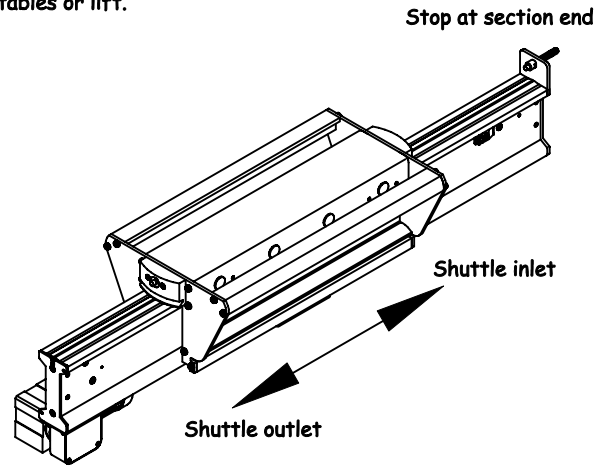

Sensor support

Reference 2017

Suitable for M12x100 sensor advisable swept area 4mm.

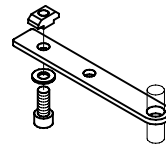

Mechanical anti-return device

Reference 2015

This device is located between stop unit ref. 2016 and the anti-lift device, it avoids unexpected movements of shuttle when operating at the working place.

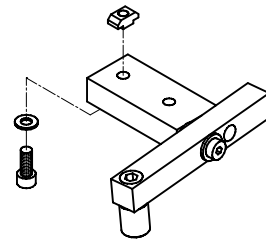

Pneumatical anti-return device

Reference 2036

This device is located between stop unit ref. 2016 and the anti-lift device, it avoids unexpected movements of shuttle during lift rising and lowering.

Simple effect pneumatic cylinder

Lubricated or not lubricated, cleaned air, 5 to 6 bars

Connection for $\varnothing 6$ mm pipe (supplied)

Detection of high and low positions by means of sensors located on the cylinder (supplied)

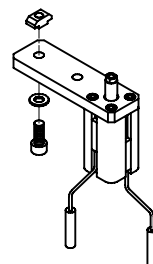

A complete range of transitic systems

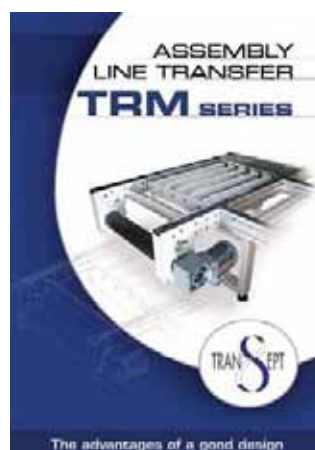
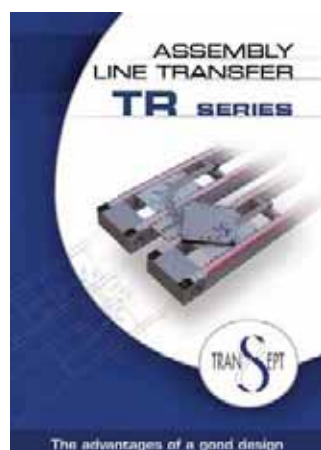

con4m GmbH
Ackerstraße 10 (Verwaltung)
Marie-Curie-Str. 3c (Lieferanschrift)
38268 Lengede

Tel. 05344 803 99 12

Fax 05344 803 99 29

Email info@con4m.com

TRANSEPT

Rue Gustave Eiffel • BP 653 • 85 306 CHALLANS Cedex • France

Tél. 33 (0)2 51 68 69 45 • Fax : 33 (0)2 51 68 81 78

www.transept.fr • e-mail : message@transept.fr